

# ADC – 9 bit 80 MHz

## 1 Features

- High speed pipeline architecture
- 1.8V Single Supply operation
- Differential input range: -1V ... +1V
- 0.18 um CMOS TSMC mixed signal technology
- Sampling rates up to 80 MHz
- Low power supply current: 30mA typical
- Power down (standby) mode
- Integral Nonlinearity: -1.0 LSB ... 1.0 LSB
- Differential Nonlinearity: -0.8LSB ... 0.8LSB
- ENOB : 8 bit ( worst case )
- Guaranteed no missing codes
- Resolution: 9 Bit
- Low input capacitance

## 2 Technology

TSMC mixed signal 0.18um CMOS process

## 3 General Description

The ADC is a high-speed pipelined analog-to-digital converter specified to operate from a nominal +1.8V single supply with tolerances of up to 10%. By implementing a 7-stage pipelined architecture with alignment and output error correction logic, the ADC offers accurate performance and guarantees no missing codes over the full operating temperature range. This complete converter also includes a biasing block, a clock generator and an output buffer.

The ADC employs digital correction techniques to provide good differential linearity for communication applications.

The ADC can be placed into a standby mode of operation reducing power below 1 microW. This power down mode along with the low single supply operation enhances its desirability in low power, battery operated applications such as mobile phones and headsets. The format of the output is 2's complement coding.

The fully differential architecture makes it insensitive to substrate noise coupling. Thus it is ideal as a mixed signal ASIC macro cell.

## 4 Block Diagram

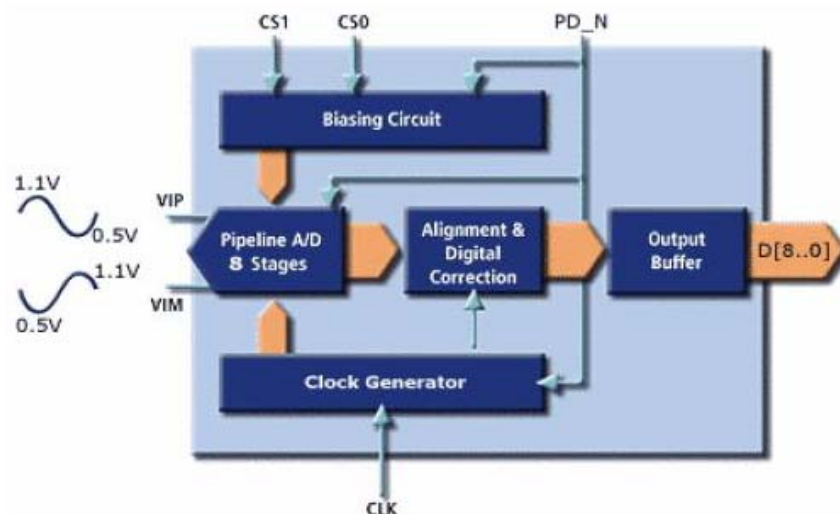

Figure 1: Functional Block Diagram

## 5 Deliverables

- GDSII
- Basic AHDL Simulation models
- Datasheets
- Application Note and Test Guidelines

## 6 Applications

- Wireless communication : WLAN etc
- Instrumentation applications
- Low power applications : mobile phones, hand helds

## 7 Specifications

Parameter	Conditions	Temp	ADC			Units
			Min	Typ	Max	
<b>RESOLUTION</b>				9		Bits
<b>TEMPERATURE RANGE</b> Specified	Ambient Air		-40		+125	°C
<b>DC ACCURACY</b> Integral Nonlinearity (INL) Differential Nonlinearity (DNL) No Missing Codes	Nominal	Full Full	-1.0 -0.8		1.0 0.8	LSB LSB
<b>DYNAMIC PERFORMANCE</b> Signal to Noise + Distortion Ratio (SINAD)  Effective Number of Bits (ENOB)  Spurious Free Dynamic Range (SFDR)	(1) see below (2) see below  (1) see below (2) see below		47.04 49.88  8.02 8.49			dB dB  bits bits
<b>POWER SUPPLIES</b> Analog Supply Voltage (vdda) Digital Supply Voltage (vdd)  Supply Current		Full Full  Full	+1.6 +1.6  	+1.8 +1.8  30	+2.0 +2.0  	V V  mA
<b>POWER CONSUMPTION</b> Specified				54		mW
<b>LOGIC INPUTS</b> Input Capacitance (C <sub>IN</sub> )				5		fF

For more details about our products and services, please contact us at [semi.ip@wipro.com](mailto:semi.ip@wipro.com).

### Wipro Technologies

Europe – Austria	India	United States	Japan
NewLogic Technologies (A Wipro Company) Millennium Park 6 A-6890 Lustenau Tel: +43-5577-995-0 Fax: +43-5577-995-988	Wipro Technologies Tower 14, 1 <sup>st</sup> floor A-Wing Keonics Electronics City Bangalore – 560100 Tel.: +91-80-3029 5121 Fax : +91-80-3029 5300	Wipro Technologies 1300, Crittenden Lane 2nd Floor, Mountain View CA 94043 Tel.: +1-650-316 3555 Fax: +1-650-316 3468	Wipro Technologies #911A, Landmark Towers 2-1-1, Minatomirai 2-Chome Nishi-Ku, Yokohama 220-8109 Tel.: +81-45-650 3950 Fax: +81-45-650 3951

[www.wipro-newlogic.com](http://www.wipro-newlogic.com), [www.wipro.com/semi-ip](http://www.wipro.com/semi-ip)

©2007 NewLogic, a Wipro Company. All Trademarks are the property of their respective owners. All information is subject to change without notice. No liability shall be incurred as a result of its use or application.